

A New Level of Clean





# RAISING THE STANDARD

A lot is on the line with the decisions you make. The health and safety of others. The reputations of those you serve. Your reputation.

You deserve a cleaning system that reflects the high standards you set. You deserve System Cleaners.

We provide professional cleaning equipment for professional cleaning people. From our extensive line of durable products to our time and money-saving technology, System Cleaners has what you need.

Our equipment is used in the production facilities of many of the top food and beverage producers in the United States and around the world. Let us show you how we can customize a cleaning solution that works to maintain the high standards you demand.



# CLEAN BY DESIGN

Our first-class systems employ time and money saving technology to help raise your facility to a new level of clean:

**Effective cleaning.** Aerosols are atomized water generated by high water pressure and may contain microorganisms. When suspended in the air, these microorganisms can re-infect clean surfaces. System Cleaners' low-pressure systems reduce the level of aerosols, limiting the threat of recontamination.

**Better heat transmission.** The large amount of spray associated with high-pressure systems allows heat to escape into the air rather than staying concentrated within the water. Our low-pressure systems, which work with a rinse pressure between 30-580 psi, retain heat by maintaining a more concentrated water flow.

**Saves both time and money.** In addition to the reduction of aerosols and temperature loss, lower atomization of water provided by low-pressure

systems ensure a higher level of impact. With our high level of impact you can clean faster and more efficiently while protecting electrical installations and processing equipment.

**User friendly.** System Cleaners' equipment allows you to perform up to three tasks with just one unit – rinse, foam and disinfect using only one outlet hose.

**Future proof.** Our modular-built workstations are designed to allow most models to be expanded with extra features. For instance, you have the ability to add extra chemical inlets even after a workstation has been installed.

**The forefront of cleaning technology.** System Cleaners has developed equipment from the very basic model to fully automated units, enabling us to offer customized solutions based on either a decentralized or centralized supply of chemicals.

# ECONOMIC

# ENVIRONMENTAL

Our systems use high-quality components to ensure up-time and long product life:

**Minimizes both service and maintenance.**

Standard primary spare parts and the latest pump technology from Grundfos reduce both service and maintenance. The water-lubricated centrifugal pumps require less maintenance than traditional oil-lubricated piston pumps.

**Promotes a healthy environment for your facility.**

The technology used by System Cleaners reduces the aerosols that expose your plant to floating bacteria. And, our systems produce less than 70db of noise, making it quieter than a household vacuum.

**Reduces costs.**

With our system's built-in functions, it is possible to make continuous cleaning systematic. This reduces the amount of time spent cleaning, warranting the possibility of improved up-time.

# CONSISTENT CLEANING

Our fully automated cleaning systems enable you to perform a consistent, high-quality cleaning.

Automation is the best option when it comes to cleaning well-defined areas requiring frequent cleaning and a high level of hygiene.

We provide customized automatic solutions, including nozzle bars, pump stations, chemical pumps and cleaning units that are compatible with our PLC or your existing PLC.

PLC systems are designed for documented and systematic cleaning to help maintain your high standards.

## AUTOMATED CLEANING SYSTEMS

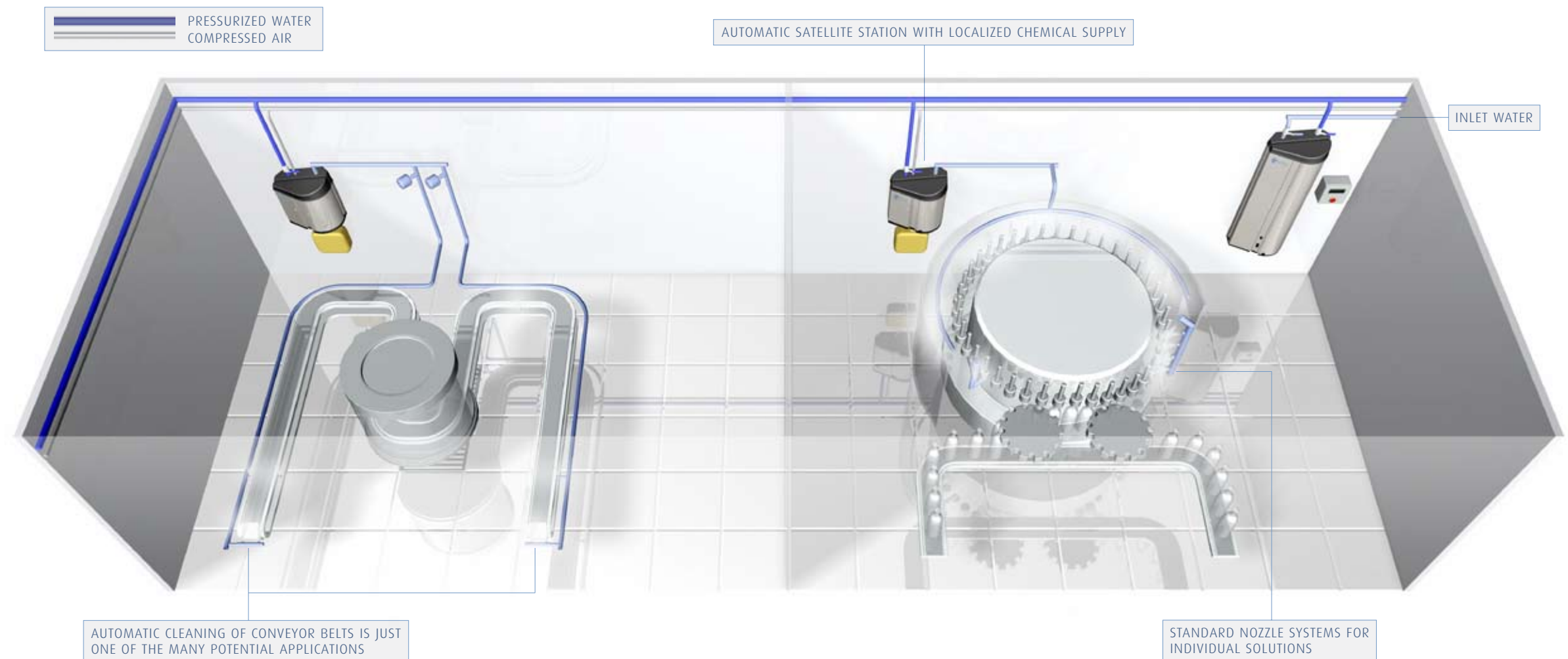

### A systematic and consistent approach to open plant cleaning

- A wide-assortment of standard nozzles and nozzle bars are guaranteed to fit almost any application
- Automatic systems can be utilized for both centralized and decentralized applications
- Ideal for a verifiable and consistent level of cleaning

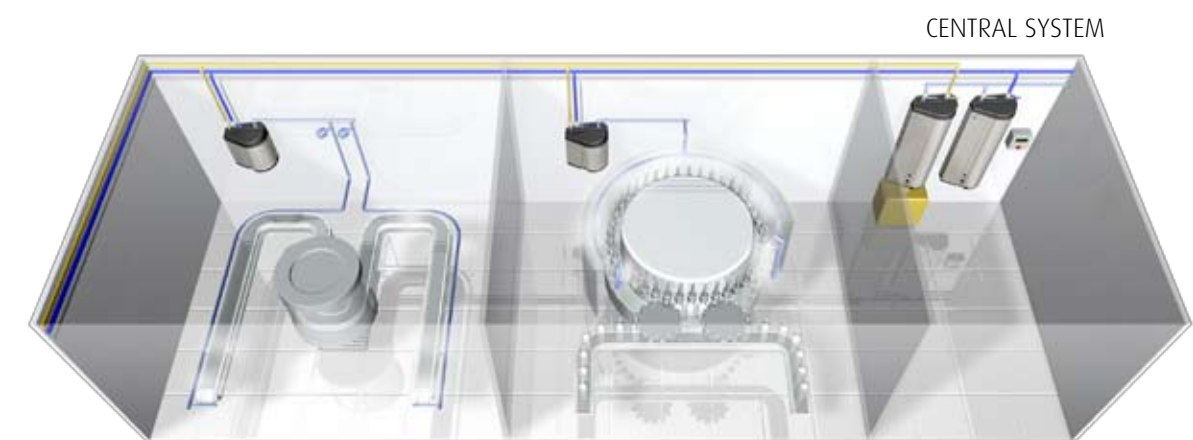
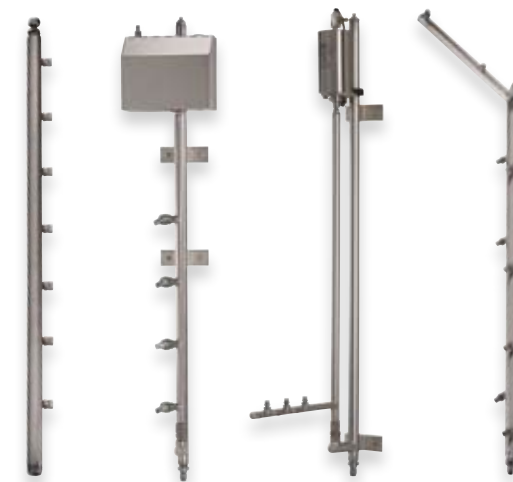

## CENTRALIZED CLEANING SYSTEMS

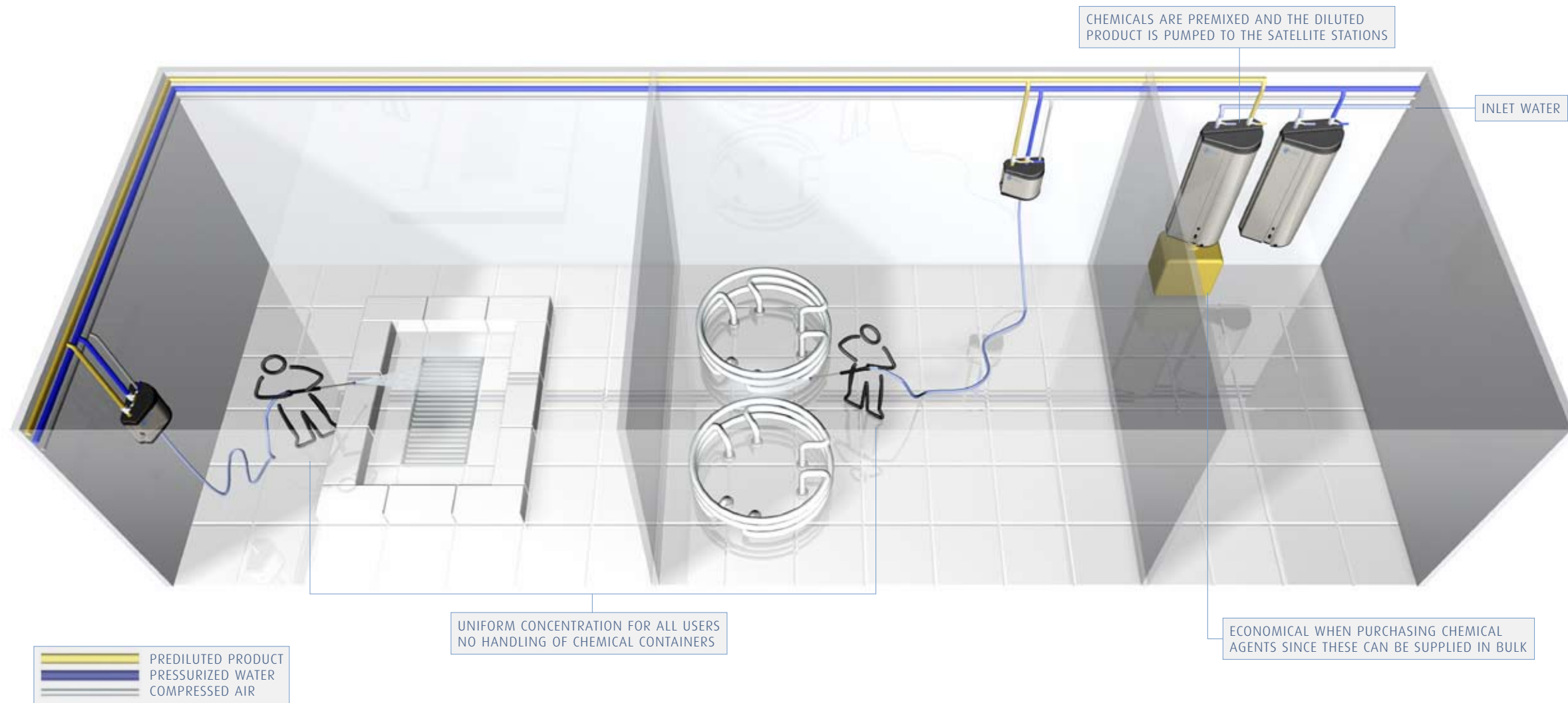

### Function and Form

- Central satellite adjustments are locked behind the stainless steel cabinet
- Future-proof kits make the satellite stations easy to upgrade
- Built-in redundancies in each unit insure both safety and accuracy
- Color-coded switches assure ease of use



# SIMPLE & SAFE

Keep your production area safer while increasing your facility's efficiency. A centralized cleaning system from System Cleaners allows a single station to distribute water and detergent throughout your entire facility.

The system consists of a pump unit to boost water pressure, a central mixing/pump station for each type of detergent and a number of satellite stations depending on what your facility requires.

Satellite stations are supplied with pre-mixed detergent from the central mixing/pump station, pressurized water from the pump station and compressed air from factory services.

With numerous options available for your satellite station, we can provide you with the right combination for your facilities.

Storing all chemicals and detergents outside of the production area promotes a safer environment for your employees since they won't have any contact with the concentrated product.

# MAXIMUM FLEXIBILITY

For cleaning that needs more individualized attention, our localized cleaning systems allow you to choose your own concentration settings as well as choose from a wide variety of satellites to meet any special needs.

A satellite station is supplied with pressurized water from a main pump station and compressed air from factory services along with its own supply of detergent and disinfectant.

A localized system can be either stand-alone or made up of a network of cleaning units supplied from the same main station or pump station.

Each satellite station is capable of performing all stages of the cleaning process - application of foam and disinfectant as well as rinsing.

With a localized system you can also take advantage of mobile units. Mobile units are great for remote areas where cleaning doesn't need to be carried out as frequently. Each unit contains a centrifugal pump and an injector system for mixing the detergent and disinfectant. Units can be equipped with a built in air compressor.

## LOCALIZED CLEANING SYSTEMS

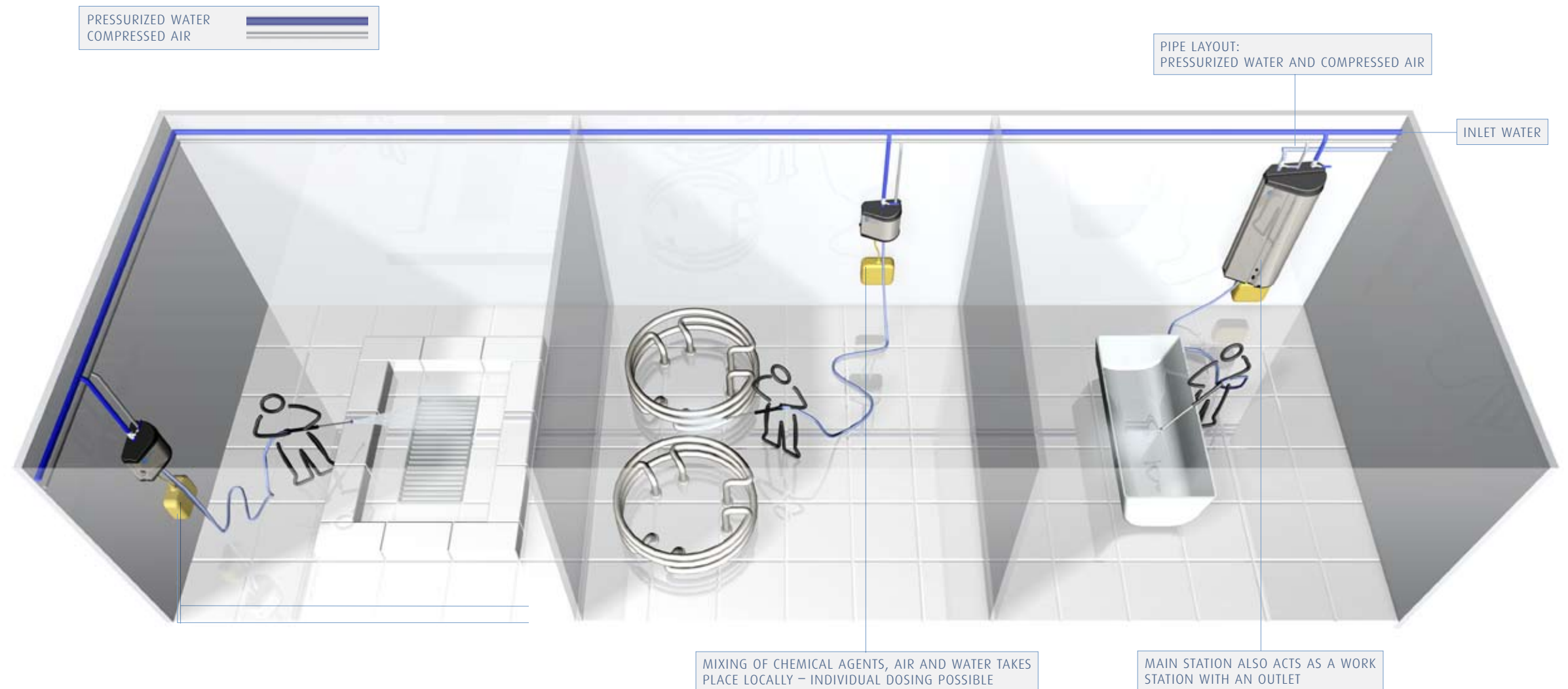

### There's more than meets the eye with our main stations and satellites

- Our systems utilize a hygienic design
- Satellite and main station have tamper-proof settings
- Future-proof kits make the stations easy to upgrade
- Our optional E-Motor is designed to create an even rinse pressure for satellites

# EXPERIENCE CLEAN

Founded 1990 in Denmark, we've grown throughout Europe and the United States because of our commitment to providing new and better cleaning technologies. We develop our products based on our own research as well as our collaborations with specialists in specific technical fields.

To watch a demonstration or learn more about any of our products, contact your System Cleaners distributor.

## A FULL LINE

We are committed to providing you with a new level of cleaning product. From durable, high-quality hoses to corrosion-resistant low-pressure valves to our full line of economy products, System Cleaners offers a wide array of options to complement your cleaning system.





8301 NW 101 Terrace, #7  
Kansas City, MO 64153

Phone: 816.285.0700  
Fax: 816.891.0550

E-mail: [contact@systemcleaners.com](mailto:contact@systemcleaners.com)  
[www.systemcleaners.com](http://www.systemcleaners.com)